

ASSEMBLY INSTRUCTIONS & PARTS MANUAL

Open ESP Shelving Models ESP-1236, ESP-1836, ESP-2436, ESP-6-1236, ESP-6-1836, ESP-6-2436



RETAIN INSTRUCTIONS FOR FUTURE REFERENCE



ESP-6-1236



ESP-2436

**LOAD CAPACITIES
PER SHELF LEVEL**

250 lbs.

GENERAL SAFETY INFORMATION

Some parts may have sharp edges. CARE must be taken when handling various pieces to avoid injury. For safety, wear a pair of work gloves when assembling or performing any maintenance on the units.

LIMITED WARRANTY

Tennsco warrants goods purchased hereunder to be free of defects in materials and workmanship for a period of one (1) year from the date of shipment, hereunder. This warranty shall not apply in the event goods are damaged as a result of misuse, abuse, neglect, accident, improper application, modification or repair by persons not authorized by Seller, where goods are damaged during shipment, or where the date stamps on the goods have been defaced, modified or removed. UNLESS CONSIDERED UNENFORCEABLE OR UNLAWFUL UNDER APPLICABLE LAW:

- a. ALL IMPLIED WARRANTIES, INCLUDING BUT NOT LIMITED TO WARRANTIES OR MERCHANTABILITY AND FITNESS FOR A PARTICULAR PURPOSE ARE HEREBY EXCLUDED;
- b. BUYERS REMEDY, IF ANY, FOR ANY DEFECTIVE GOODS SHALL BE LIMITED TO A REFUND BY SELLER OR REPLACEMENT OF THE GOODS AT SELLER'S OPTION, AND SHALL IN NO EVENT INCLUDE DAMAGES OF ANY KIND, WHETHER INCIDENTAL, CONSEQUENTIAL OR OTHERWISE.

NO GOODS ACCEPTED FOR RETURN WITHOUT PRIOR APPROVAL. Seller shall have the right to inspect any goods claimed to be defective at Buyers place of business or require Buyer to return the goods to Seller for inspection on Seller's premises. Transportation charges covering returned goods will be borne by Seller only if such goods are proven to be defective, are covered by this warranty and are returned within the warranty period stated above.



PROUDLY MADE IN THE U.S.A.

Tennsco LLC., Dickson, TN 37056-1888 • (866) 446-8686

ASSEMBLY OF OPEN ESP SHELVING

Two people are recommended for assembly. Approximate assembly time: 10-15 minutes.

1. The reference numbers used throughout this sheet refer to the illustration on the back cover. This is to help you to identify the various parts as they are mentioned.
2. Lay the two corner posts (Ref. No. 1) parallel on the floor or on saw horses with the short sides facing up.

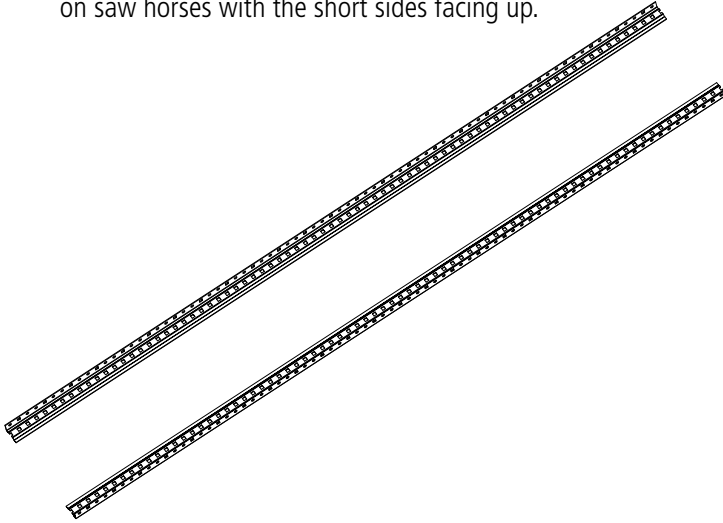

3. Create an upright assembly by bolting a side sway plate (Ref. No. 3) 10 holes down from the top of both corner posts, connecting them together. Then bolt another side sway plate ten holes up from the bottom on both corner posts.

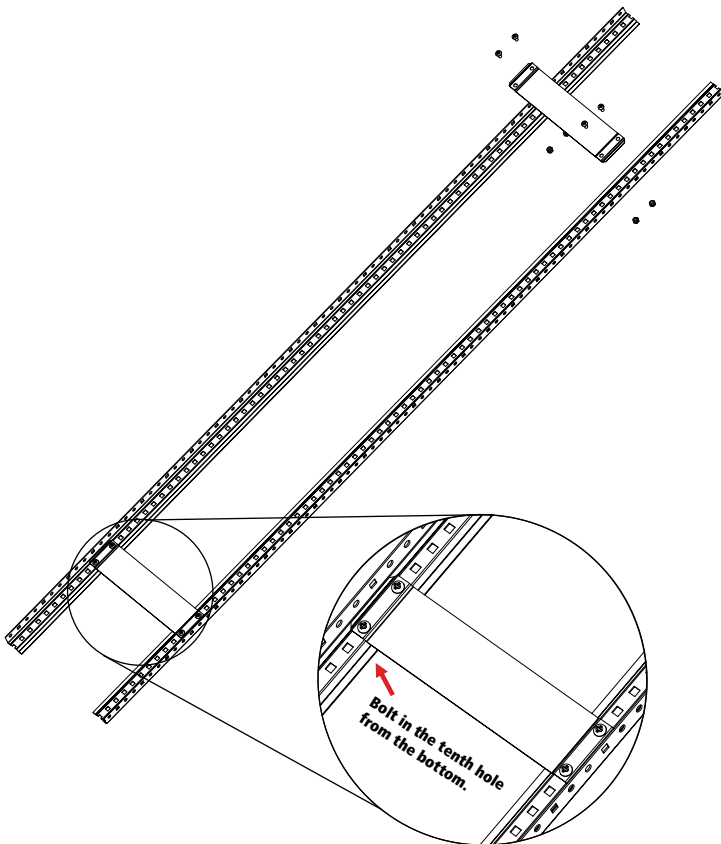

4. Place the upright assembly to the side and repeat the first two steps on the remaining corner posts, creating a second upright assembly. Place shelf clips (Ref. No. 7) in the top and bottom holes of all four posts.

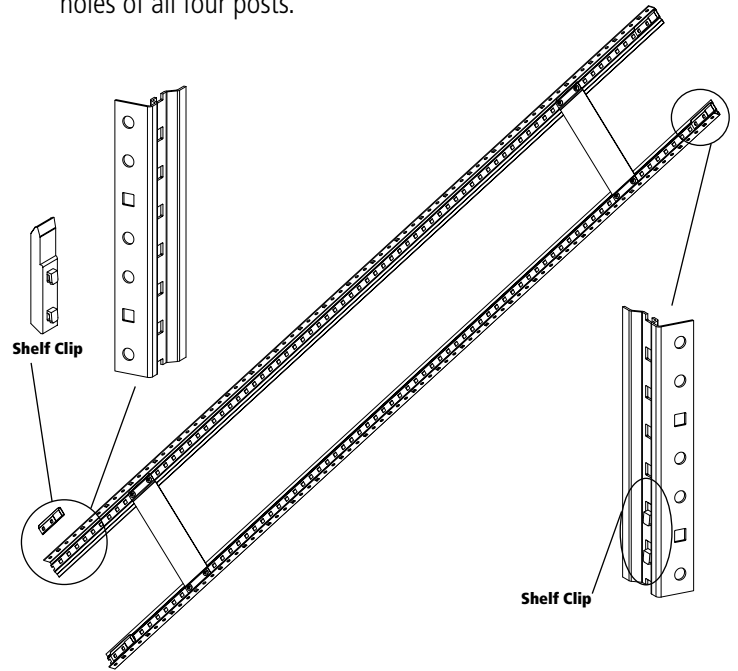

5. Lean one upright assembly against a wall or another stable surface and place a shelf (Ref. No. 2) on the bottom clips of the post.

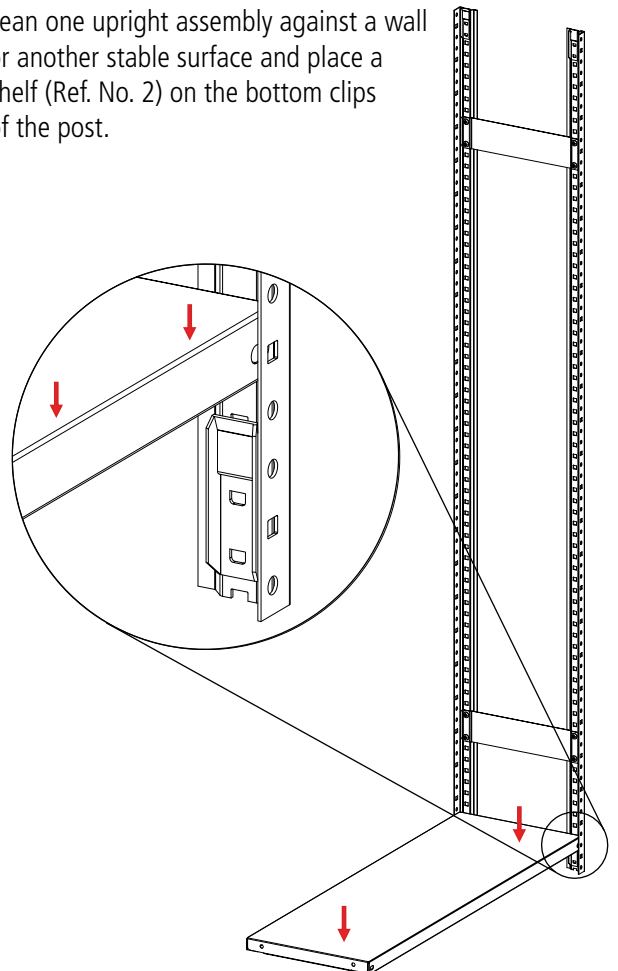

6. Place the second upright assembly in place with the bottom shelf and hook the shelf in over the bottom clips.

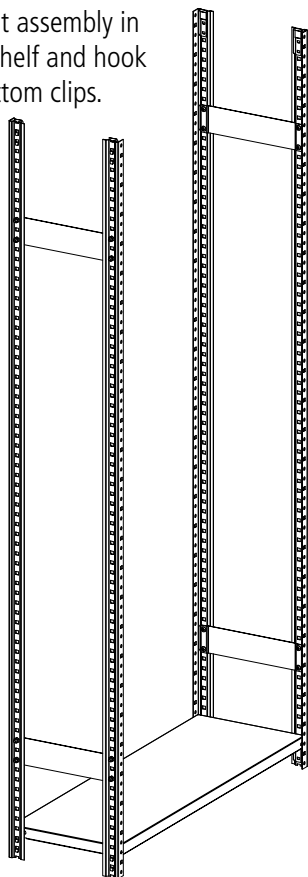

7. Place the top shelf over the four clips at the top of the posts.

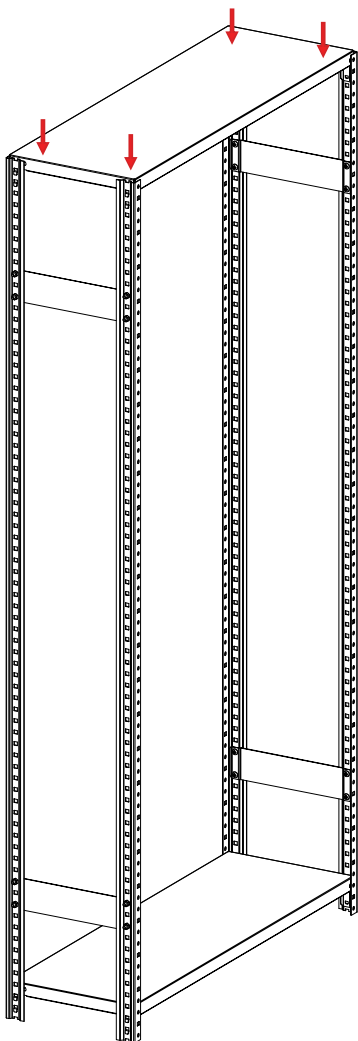

8. Bolt the rear sway braces (Ref. No. 4) in place. The top brace should be in the 27th hole from the top of the posts. Be sure they are stretched to full extension; otherwise the braces will appear loose.

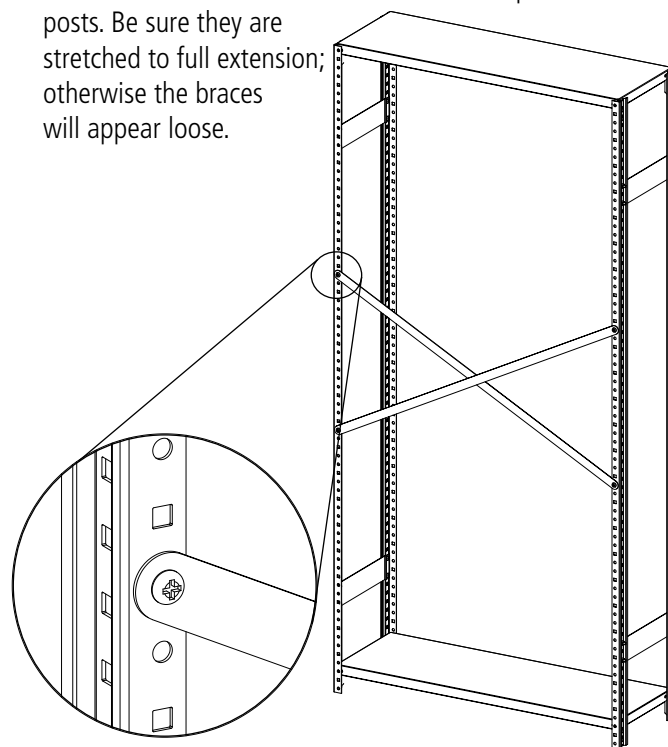

NOTE: If sway braces interfere with your desired shelf placement, they may be moved one hole up or down on the unit.

9. Position the remaining shelves where desired, making sure each shelf is supported by four clips. Before loading the shelves, make sure all bolts and nuts are securely tightened.

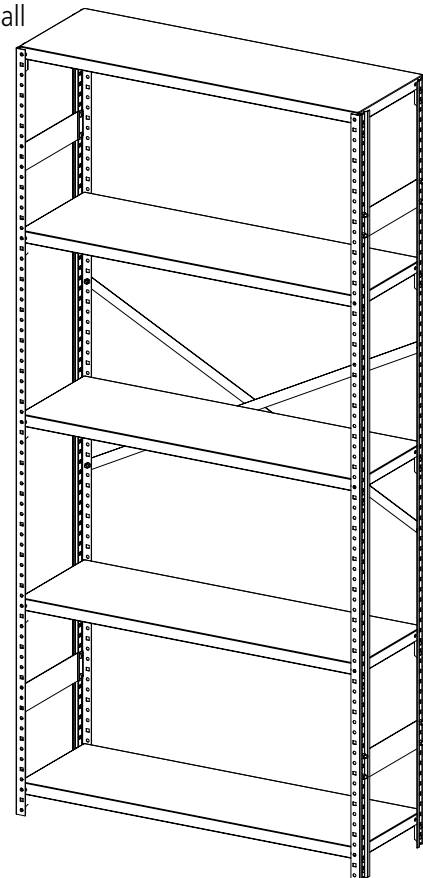

REPLACEMENT PARTS

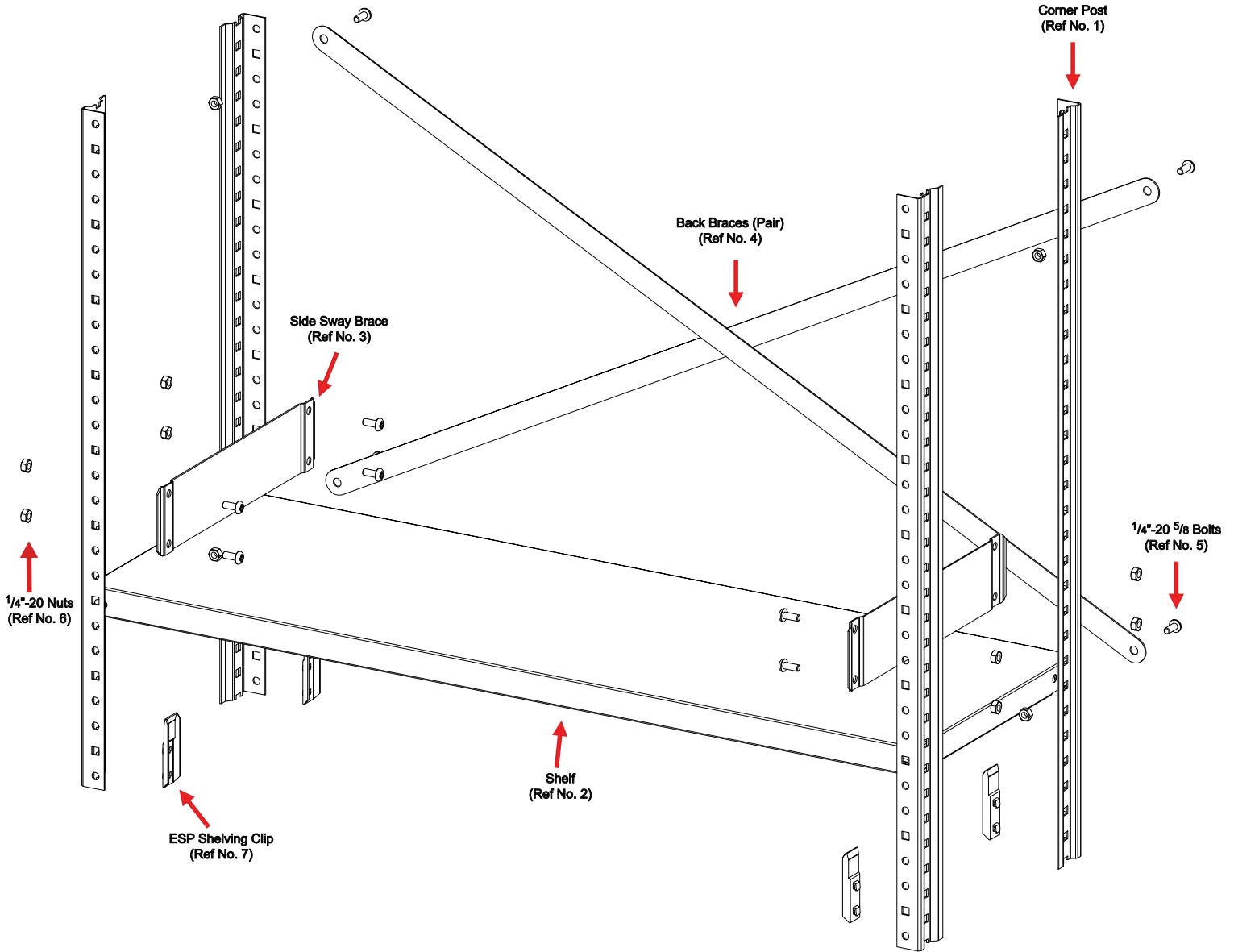

REF. NO.	DESCRIPTION	PART NO.	36w x 12d		36w x 18d		36w x 24d	
			ESP-1236	ESP-6-1236	ESP-1836	ESP-6-1836	ESP-2436	ESP-6-2436
1	Corner Post	SSP-75	4	4	4	4	4	4
2	Shelves	ES-12	5	6				
		ES-18			5	6		
		ES-24					5	6
3	Side Sway Braces	SSB-12	4	4				
		SSB-18			4	4		
		SSB-24					4	4
4	Back Braces (Pair)	SBB-36	1	1	1	1	1	1
5	1/4"-20 5/8" Bolts	*	20	20	20	20	20	20
6	1/4"-20 Nuts	*	20	20	20	20	20	20
7	ESP Shelving Clips	ESPCLIP	20	20	20	20	20	20

NOTE: Additional hardware may be included for replacement purposes.

Tennsco makes every effort to ensure that all units ship complete with all parts and arrive undamaged. However, should your unit contain missing or damaged parts, please contact your purchase location.